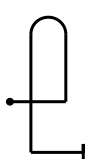
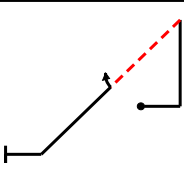
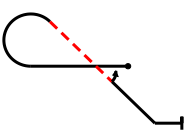
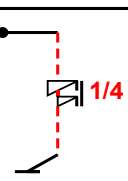
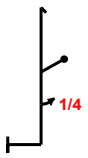
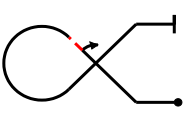
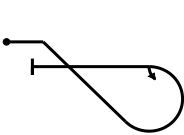
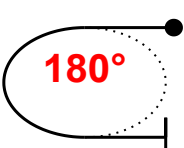
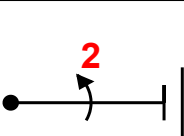

Pilot ID

AAC Sportsman Known

Flight #

No	Symbol	Cat. No.	K	Total K	Grade	Pos	Remarks	Item	K	Grade
1		8.4.1.1	13	13	.			Pos.	15	
								Harm.	0	
2		1.2.7.1 9.1.4.2	13 4	17	.			Fig K	Total K	
								133	148	
3		8.5.6.1 9.1.4.2	10 4	14	.			Penalties		
								Too Low		
								Too High		
								Interruptions		
								Insertions		
								Trg Violation		
								Wing Rocks		
Disqual Fig										
Other(note...)										
5		1.1.6.3 9.11.1.5	10 4	14	.			Final Freestyle		
								Duration	Min	Sec
6		5.2.1.1 9.1.5.1	17 2	19	.			Judges Details		
								Signature		
7		7.3.2.1 9.1.2.2	14 6	20	.			Name		
								Number		
8		8.5.3.3 9.1.3.2	10 4	14	.					
9		2.2.1.1	4	4	.					
10		1.1.1.1 9.2.3.4	2 9	11	.					

Pilot

A/C

← wind/vent

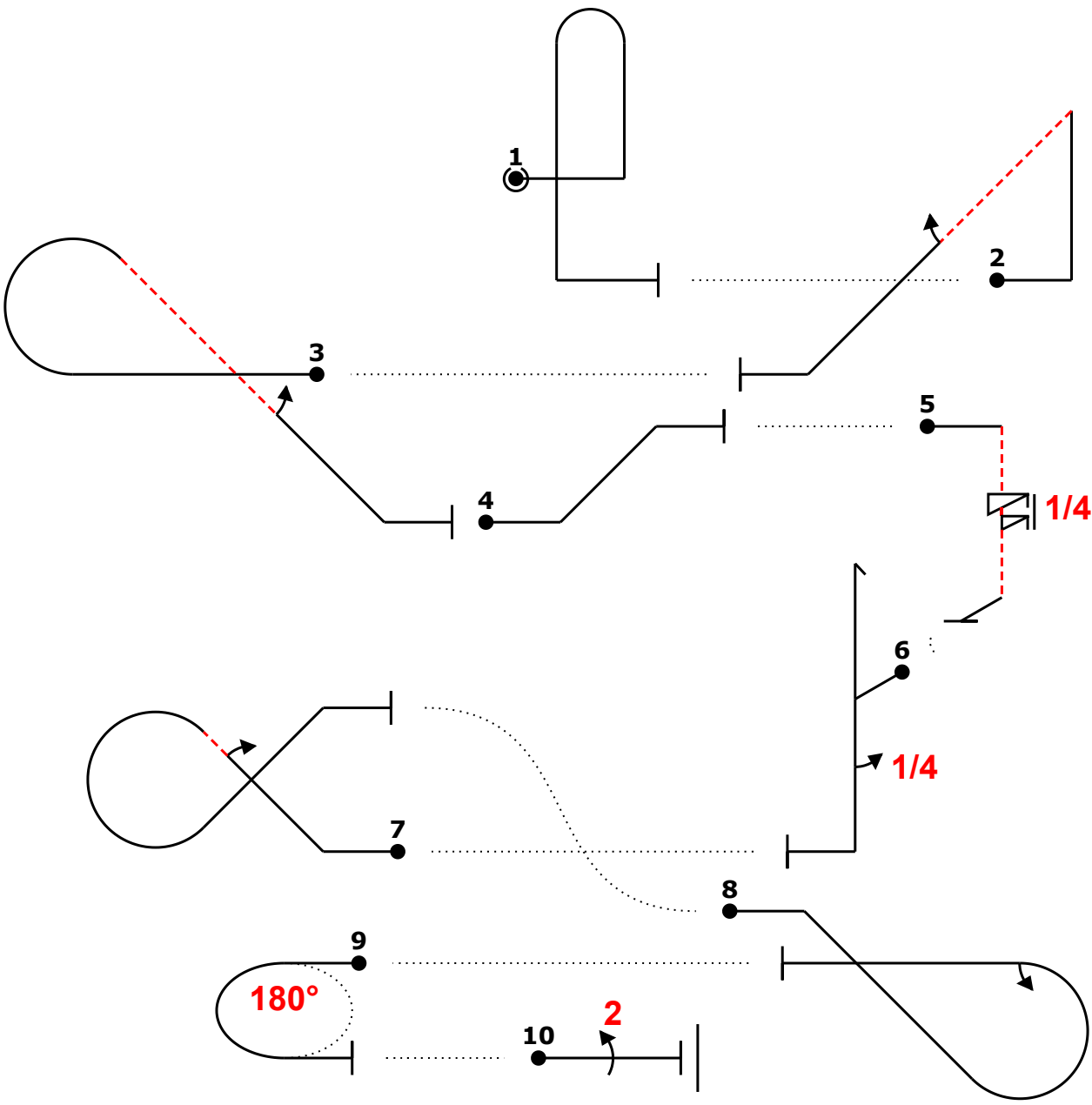

Power			
Fig	Aresti	K	
1	8.4.1.1	13	13
2	1.2.7.1 9.1.4.2	13 4	17
3	8.5.6.1 9.1.4.2	10 4	14
4	1.1.2.1	7	7
5	1.1.6.3 9.11.1.5	10 4	14
6	5.2.1.1 9.1.5.1	17 2	19
7	7.3.2.1 9.1.2.2	14 6	20
8	8.5.3.3 9.1.3.2	10 4	14
9	2.2.1.1	4	4
10	1.1.1.1 9.2.3.4	2 9	11
Total K = 133			

Pilot
A/C

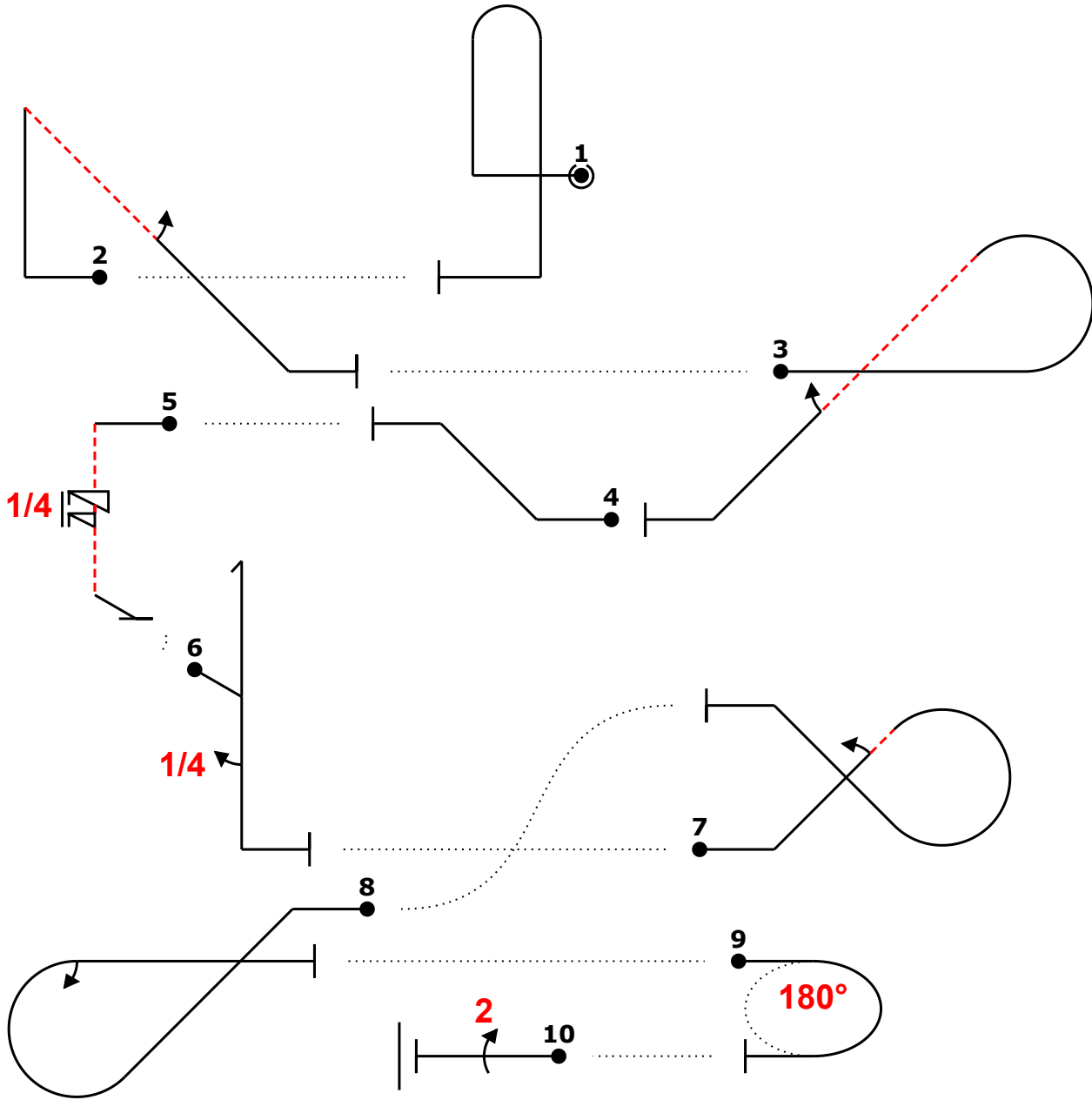
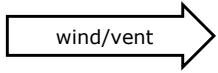

Power			
Fig	Aresti	K	
1	8.4.1.1	13	13
2	1.2.7.1 9.1.4.2	13 4	17
3	8.5.6.1 9.1.4.2	10 4	14
4	1.1.2.1	7	7
5	1.1.6.3 9.11.1.5	10 4	14
6	5.2.1.1 9.1.5.1	17 2	19
7	7.3.2.1 9.1.2.2	14 6	20
8	8.5.3.3 9.1.3.2	10 4	14
9	2.2.1.1	4	4
10	1.1.1.1 9.2.3.4	2 9	11
Total K = 133			

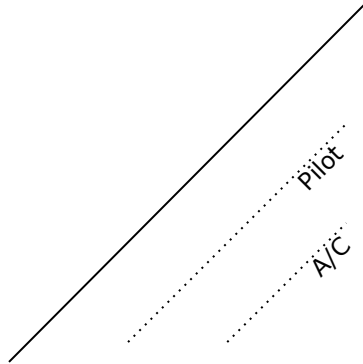



AAC Sportsman 2020
Known

Figure K
133
Total K
148

Judges Name
Signature Number

Flight #

wind/vent ← R

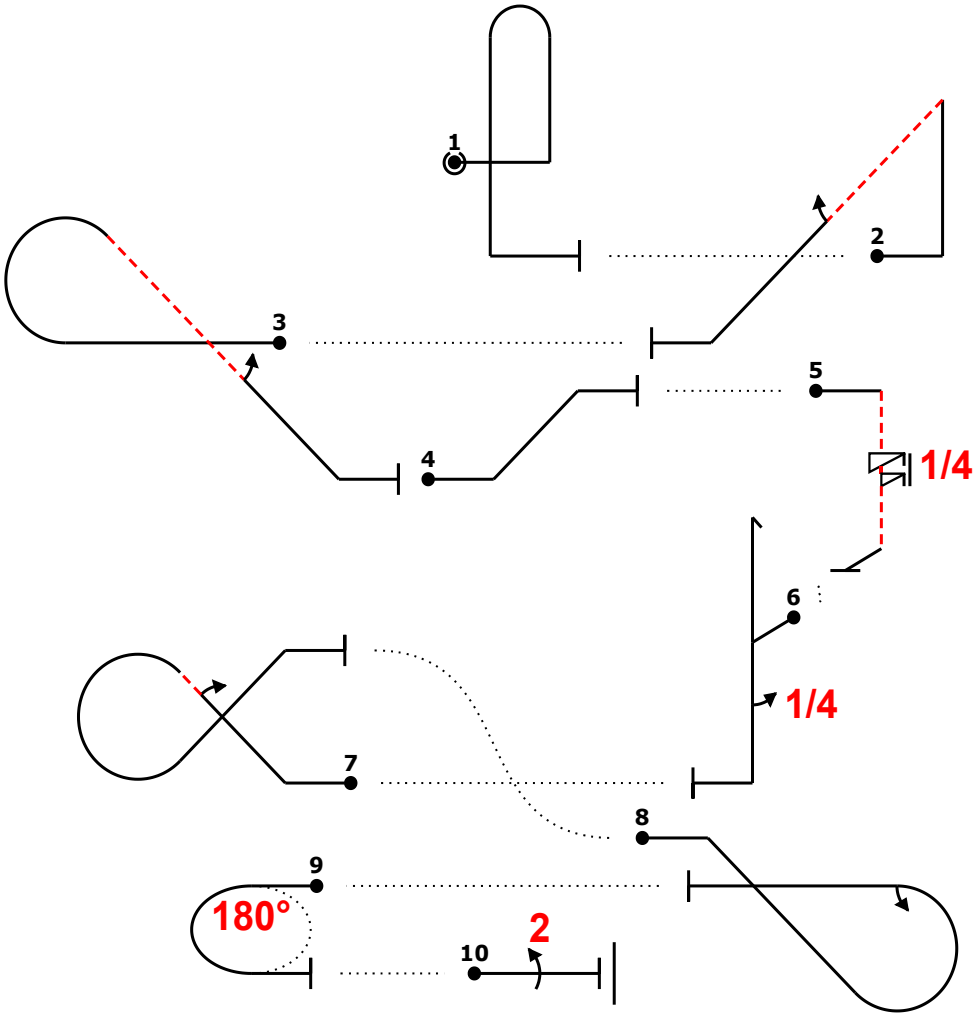

Fig	Grade	Pos	Remarks
1	.		
2	.		
3	.		
4	.		
5	.		
6	.		
7	.		
8	.		
9	.		
10	.		

Positioning
15 .

Too Low		Trg Violation	
Too High		Wing Rocks	
Interruptions		Disqual Fig	
Insertions		Other(note...)	

b.' (16,0) k.,2. (-21,0) c... '2 d (8,0) iv5s (0,1) h4. (-19,0) ,2g (16,12) irc2 (-21,0) 2j (7,0) 22

Fig 1	K	Fig 2	K	Fig 3	K	Fig 4	K	Fig 5	K	Fig 6	K	Fig 7	K	Fig 8	K	Fig 9	K	Fig 10	K
8.4.1.1	13	1.2.7.1	13	8.5.6.1	10	1.1.2.1	7	1.1.6.3	10	5.2.1.1	17	7.3.2.1	14	8.5.3.3	10	2.2.1.1	4	1.1.1.1	2
		9.1.4.2	4	9.1.4.2	4			9.11.1.5	4	9.1.5.1	2	9.1.2.2	6	9.1.3.2	4			9.2.3.4	9
	13		17		14		7		14		19		20		14		4		11

Pilot:

A/C:

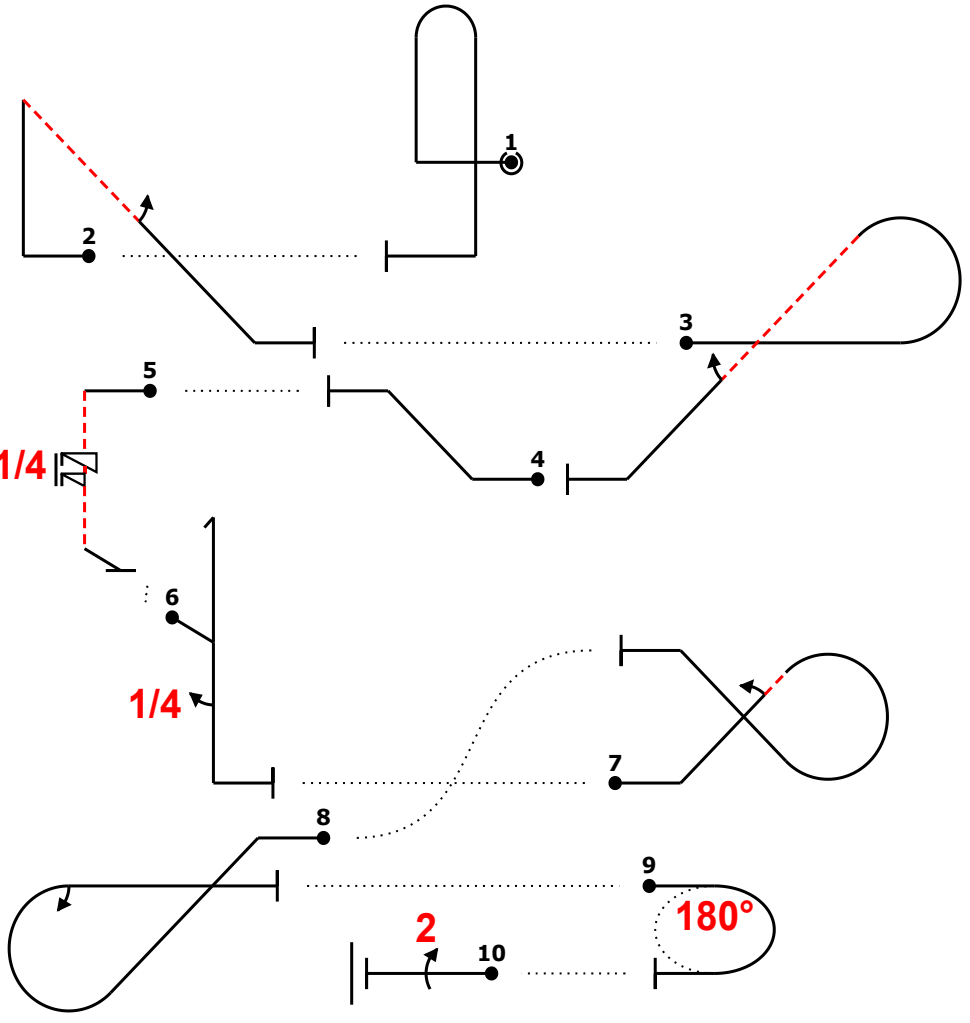
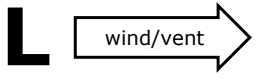

Fig	Grade	Pos	Remarks
1	.		
2	.		
3	.		
4	.		
5	.		
6	.		
7	.		
8	.		
9	.		
10	.		

Positioning
15 .

Too Low		Trg Violation	
Too High		Wing Rocks	
Interruptions		Disqual Fig	
Insertions		Other(note...)	

b.' (16,0) k.,2. (-21,0) c... '2 d (8,0) iv5s (0,1) h4. (-19,0) ,2g (16,12) irc2 (-21,0) 2j (7,0) 22

Fig	K	Fig	K	Fig	K	Fig	K	Fig	K	Fig	K	Fig	K	Fig	K	Fig	K
8.4.1.1	13	1.2.7.1	13	8.5.6.1	10	1.1.2.1	7	1.1.6.3	10	5.2.1.1	17	7.3.2.1	14	8.5.3.3	10	2.2.1.1	4
		9.1.4.2	4	9.1.4.2	4			9.11.1.5	4	9.1.5.1	19	9.1.2.2	6	9.1.3.2	4		
	13		17		14		7		14		19		20		14		4

Pilot:

A/C:

wind/vent

